

## MRW Disc Brake Caliper - Mechanically Applied, Hand Operated

Nominal dimensions are given

For caliper dimensions see DS2000

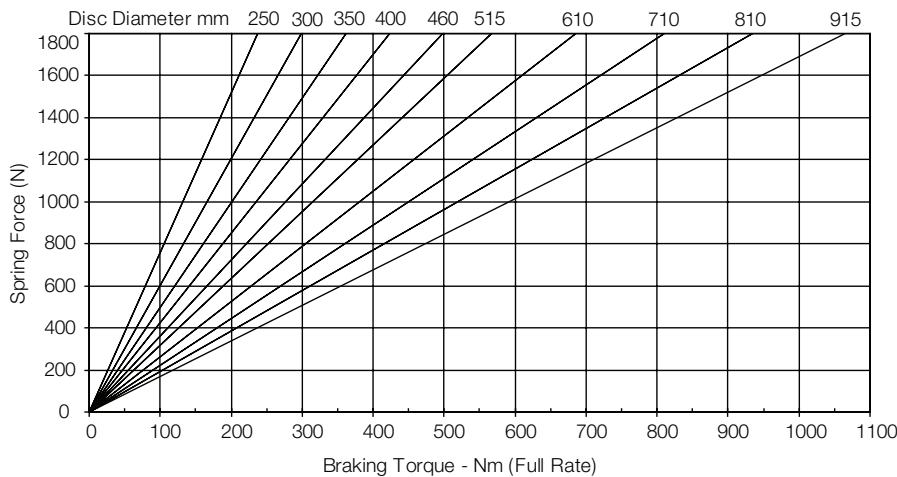
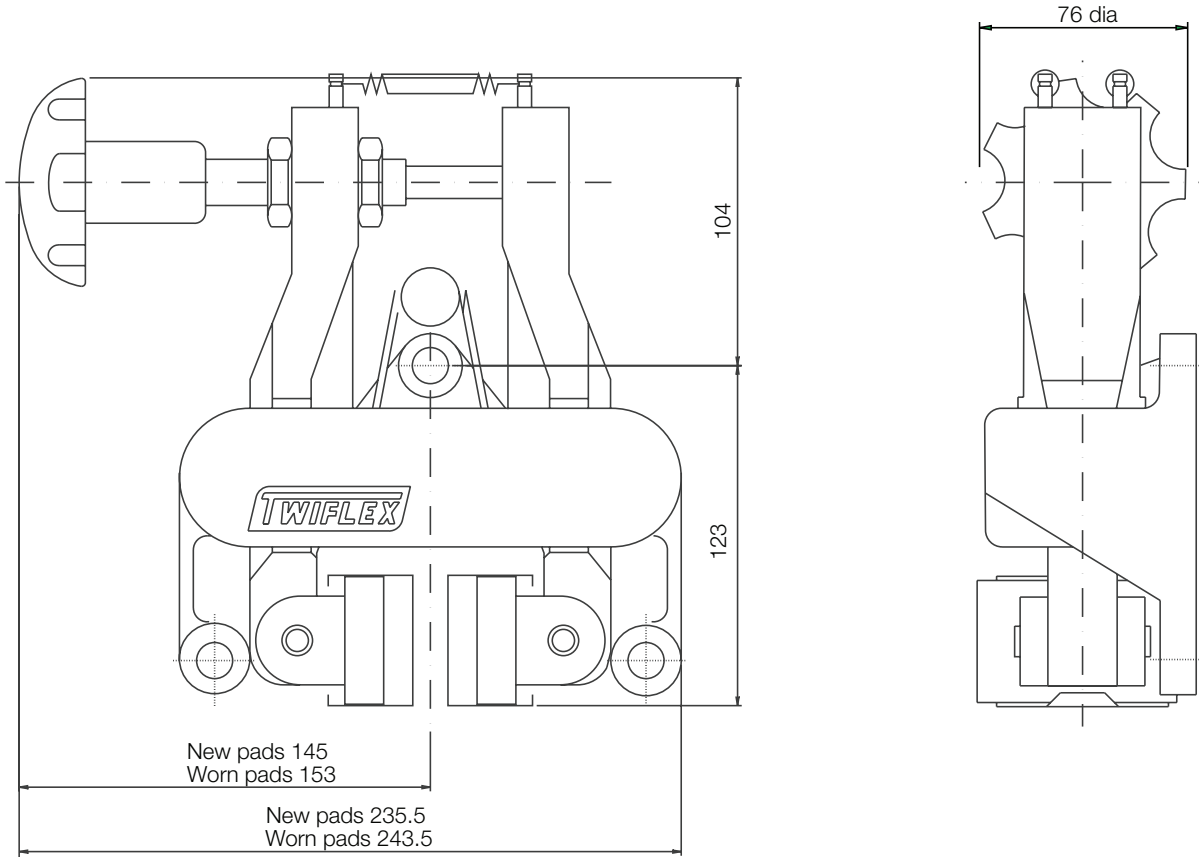

Weight (caliper and hand knob) - 7.8kg  
 (hand knob only) - 1.3kg

**1 turn of hand knob = 150N braking force**  
**Maximum Braking Force = 2.68kN**

The ratings shown on the above graph are based on fully bedded and conditioned brake pads with nominal friction coefficient  $\mu=0.4$ .

For bedding-in and conditioning procedures see Publication M1060.

Braking Force is defined as the Tangential Force acting on the brake disc at the Effective Disc Radius.

Braking Torque (Nm) = Braking Force (N) x Effective Disc Radius (m) where Effective Disc Radius = Actual Disc Radius - 0.03.

Twiflex Disc Brakes must be used with Twiflex asbestos free brake pads. The use of any other brake pads will invalidate the warranty. Twiflex Limited reserves the right to modify or change the design without prior notice.

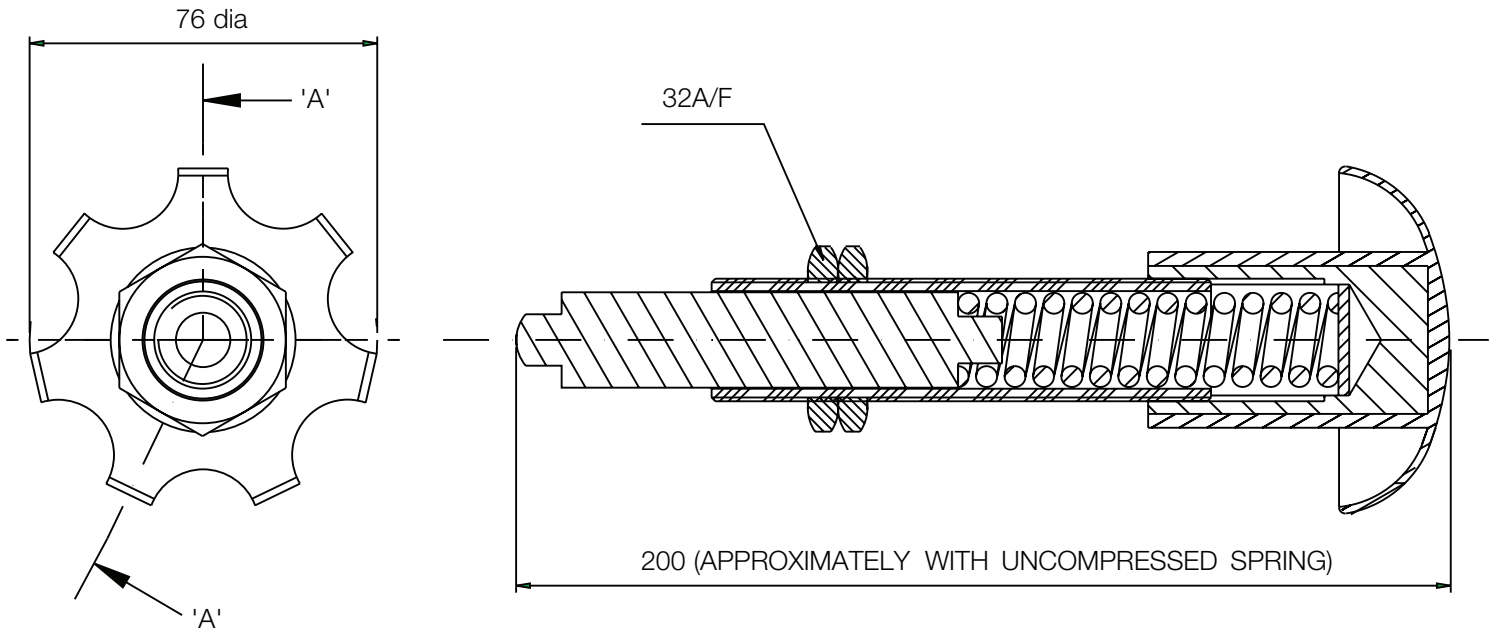

## Hand Knob Assembly Part Number 7800126

### Thruster Fitment

1. Offer hand knob assembly to caliper making sure that one lock nut is removed before placing push rod through caliper arm.
2. Fit a lock nut over the push rod and locate the push rod within the slot of the opposite arm.
3. Adjust the lock nuts until the push rod contacts the opposite arm.
4. Tighten the lock nuts to 50-60Nm.

